



Emissions Test Report

EUT Name: NOTE

Model No.: WBGLW

FCC KDB 996369 D04 Module Integration Guide v02

Prepared for:

Blues, Inc.
50 Harbor St
Manchester, MA 01944

Prepared by:

Bureau Veritas Consumer Products Services, Inc.
775 Montague Expressway,
Milpitas, CA 95035
Tel: (408) 526-1188
<https://group.bureauveritas.com/>

Report/Issue Date: September 15, 2023
Revision Number 0
Report Number: CJJJ-TNY-P23060073-3

Revisions

Revision No.	Date MM/DD/YYYY	Reason for Change	Author
0	09/15/2023	Original Document	BQ
1	06/24/2024	Model Name Update	IMA

Note: Latest revision report will replace all previous reports.

Statement of Compliance

Manufacturer: Blues, Inc.
50 Harbor St
Manchester, MA 01944

Requester / Applicant: Blue, Inc. (same as manufacturer)

Name of Equipment: NOTE
Model No 's: WBGLW
Application of Regulations: 47 CFR Part 2, RSS-GEN
47 CFR Part 22 Subpart H, RSS-132
47 CFR Part 24 Subpart E, RSS-133

Test Dates: July 20, 2023 to July 27, 2023

Guidance Documents:
Emissions: FCC KDB 996369 D04 Module Integration Guide v02,

Test Methods:
Emissions: ANSI C63.26:2015

This report is for your exclusive use. Any copying or replication of this report to or for any other person or entity, or use of our name or trademark, is permitted only with our prior written permission. This report sets forth our findings solely with respect to the test samples identified herein. The results set forth in this report are not indicative or representative of the quality or characteristics of the lot from which a test sample was taken or any similar or identical product unless specifically and expressly noted. Our report includes all of the tests requested by you and the results thereof based upon the information that you provided to us. You have 60 days from date of issuance of this report to notify us of any material error or omission caused by our negligence, provided, however, that such notice shall be in writing and shall specifically address the issue you wish to raise. A failure to raise such issue within the prescribed time shall constitute your unqualified acceptance of the completeness of this report, the tests conducted and the correctness of the report contents. Unless specific mention, the uncertainty of measurement has been explicitly taken into account to declare the compliance or non-compliance to the specification. The report must not be used by the client to claim product certification, approval, or endorsement by A2LA or any government agencies.



Brandon Quan

Test Engineer

Date Sep. 15, 2023



Suresh Kondapalli

Reviewer Signatory

Date Sep. 15, 2023



Testing Cert #2742-01



US1109



4842D

1	<i>Executive Summary</i>	5
1.1	Scope.....	5
1.2	Purpose.....	5
1.3	Summary of Test Results.....	6
1.4	Special Accessories.....	6
1.5	Equipment Modifications.....	6
2	<i>Laboratory Information</i>	7
2.1	Accreditations & Endorsements	7
2.1.1	US Federal Communications Commission.....	7
2.1.2	NIST / A2LA.....	7
2.1.3	Canada.....	7
2.1.4	Japan – VCCI.....	7
2.1.5	Acceptance by Mutual Recognition Arrangement.....	7
2.2	Test Facilities	8
2.2.1	Emission Test Facility.....	8
2.3	Measurement Uncertainty	8
2.3.1	Sample Calculation – radiated & conducted emissions.....	8
2.3.2	Measurement Uncertainty.....	9
2.4	Calibration Traceability	9
3	<i>General Information</i>	10
3.1	Description of EUT.....	10
4	<i>Configuration and Connections with EUT</i>	12
4.1	Features of EUT.....	12
5	<i>Emissions</i>	13
5.1	Transmit Spurious Emissions	13
5.1.1	Test Methodology.....	13
5.1.2	Transmitter Spurious Emission Limit.....	14
5.1.3	Test Results.....	15
5.1.4	Sample Calculation.....	27
6	<i>EUT TEST SETUP Photos</i>	28
7	<i>Test Equipment List</i>	31
7.1	Equipment List.....	31

1 Executive Summary

1.1 Scope

This report is intended to document the status of conformance with the requirements of the FCC KDB 996369 D04 Module Integration Guide v02 based on the results of testing performed on July 20, 2023 to July 27, 2023 on the Blues NOTE Model WWXD/WGBLW. This report only applies to the specific samples tested under the stated test conditions. It is the responsibility of the manufacturer to ensure that additional production units of this model are manufactured with identical or EMI equivalent electrical and mechanical components. This report is further intended to document changes and modifications to the EUT throughout its life cycle. All documentation will be included as a supplement.

1.2 Purpose

Testing was performed to evaluate the EMC performance of the EUT in accordance with the applicable requirements, procedures, and criteria defined in the application of regulations and application of standards listed in this report. This report documents the integration of the fully certified module; FCC ID: RI7LE910CXWWX.

1.3 Summary of Test Results

Table 1: Summary of Test Results

Test	Band	Test Method/ Regulations	Requirements	Result
	Spurious Emission in Transmitted Mode	LTE Band 5		
WCDMA Band 2		CFR47 Part 2.1053; 24.238 RSS-GEN 5, 6.13	FCC: ≤ -13 dBm/1 MHz	Complied
GSM 1900		RSS-133, 6.5		Complied

1.4 Special Accessories

No special accessories were necessary in order to achieve compliance.

1.5 Equipment Modifications

None.

2 Laboratory Information

2.1 Accreditations & Endorsements

2.1.1 US Federal Communications Commission



Bureau Veritas Consumer Products Services, Inc. at 775 Montague Expressway, Milpitas CA 95035 is recognized by the commission for performing testing services for the general public on a fee basis. These laboratory test facilities have been fully described in reports submitted to and accepted by the FCC (Registration No. US1109). The laboratory scope of accreditation includes: Title 47 CFR Parts 15, 18, 20, 22, 24, 25, 27, 90, 95, 97 and 101. The accreditation is updated every 3 years.

2.1.2 NIST / A2LA



Bureau Veritas Consumer Products Services, Inc is accredited by the National Voluntary Laboratory Accreditation Program, which is administered under the auspices of the National Institute of Standards and Technology. The laboratory has been assessed and accredited in accordance with ISO Guide 17025:2017 and ISO 9002 (Lab Code 2742-01). The scope of laboratory accreditation includes emission and immunity testing. The accreditation is updated annually.

2.1.3 Canada



Bureau Veritas Consumer Products Services, Inc. at the 775 Montague Expressway, Milpitas, CA 95035 address is accredited by Industry Canada for

performing testing services for the general public on a fee basis. This laboratory test facilities have been fully described in reports submitted to and accepted by Industry Canada (File Number 4842D). This reference number is the indication to the Industry Canada Certification Officers that the site meets the requirements of RSS 212, Issue 1 (Provisional). The accreditation is updated every 3 years.

2.1.4 Japan – VCCI



The Voluntary Control Council for Interference by Information Technology Equipment (VCCI) is a group that consists of Information Technology Equipment (ITE) manufacturers and EMC test laboratories. The purpose of the Council is to take voluntary control measures against electromagnetic interference from Information Technology Equipment, and thereby contribute to the development of a socially beneficial and responsible state of affairs in the realm of Information Technology Equipment in Japan. Bureau Veritas Consumer Products Services, Inc. at 775 Montague Expressway, Milpitas, CA 95035 has been assessed and approved in accordance with the Regulations for Voluntary Control Measures.

VCCI Registration No. for for Milpitas: A-0133

2.1.5 Acceptance by Mutual Recognition Arrangement

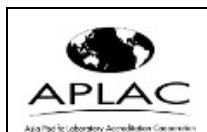

The United States has an established agreement with specific countries under the Asia Pacific Laboratory Accreditation Corporation (APLAC) Mutual Recognition Arrangement. Under this agreement, all Bureau Veritas Consumer Products Services, Inc. at 775 Montague Expressway, Milpitas, CA 95035 test results and test reports within the scope of the laboratory NIST / A2LA

accreditation will be accepted by each member country.

2.2 Test Facilities

All of the test facilities are located at 775 Montague Expressway, Milpitas, California, 95035, USA.

2.2.1 Emission Test Facility

The Semi-Anechoic chamber and AC Line Conducted measurement facility used to collect the radiated and conducted data has been constructed in accordance with ANSI C63.7:1992. The site has been measured in accordance with and verified to comply with the theoretical normalized site attenuation requirements of ANSI C63.4-2014, at a test distance of 3 and 10 meters. The site is listed with the FCC and accredited by A2LA (Lab Code 2742-01). A report detailing this site can be obtained from Bureau Veritas Consumer Products Services, Inc.

2.3 Measurement Uncertainty

Two types of measurement uncertainty are expressed in this report, per *ISO Guide To The Expression Of Uncertainty In Measurement*, 1st Edition, 1995.

The Combined Standard Uncertainty is the standard uncertainty of the result of a measurement when that result is obtained from the values of a number of other quantities; it is equal to the positive square root of the sum of the variances or co-variances of these other quantities, weighted according to how the measurement result varies with changes in these quantities. The term *standard uncertainty* is the result of a measurement expressed as a standard deviation.

2.3.1 Sample Calculation – radiated & conducted emissions

The field strength is calculated by subtracting the Amplifier Gain and adding the Cable Loss and Antenna Correction Factor to the measured reading. The basic equation is as follows:

$$\text{Field Strength (dB}\mu\text{V/m)} = \text{RAW} - \text{AMP} + \text{CBL} + \text{ACF}$$

Where: RAW = Measured level before correction (dB μ V)

AMP = Amplifier Gain (dB)

CBL = Cable Loss (dB)

ACF = Antenna Correction Factor (dB/m)

$$\mu\text{V/m} = 10^{\frac{\text{dB}\mu\text{V/m}}{20}}$$

Sample radiated emissions calculation @ 30 MHz

Measurement +Antenna Factor–Amplifier Gain+Cable loss=Radiated Emissions (dBuV/m)

$$25 \text{ dBuV/m} + 17.5 \text{ dB} - 20 \text{ dB} + 1.0 \text{ dB} = 23.5 \text{ dBuV/m}$$

2.3.2 Measurement Uncertainty

Where relevant, the following measurement uncertainty levels have been estimated for tests performed on the EUT as specified in CISPR 16-4-2:

MEASUREMENT	FREQUENCY	UNCERTAINTY
Conducted emissions	0.15 MHz ~ 30 MHz	2.70 dB
Radiated emissions	9 kHz ~ 30 MHz	2.16 dB
	30 MHz ~ 1 GHz	3.60 dB
	1 GHz ~ 18 GHz	4.82 dB
	18 GHz ~ 40 GHz	5.00 dB

This uncertainty represents an expanded uncertainty expressed at approximately the 95% confidence level using a coverage factor of $k = 2$.

2.4 Calibration Traceability

All measurement instrumentation is traceable to the National Institute of Standards and Technology (NIST). Measurement method complies with ANSI/NCSL Z540-1-1994 and ISO Standard 17025:2017. Equipment calibration records are kept on file at the test facility.

3 General Information

3.1 Description of EUT

Product	Notecard					
Brand	Blues, Inc.					
Test Model	NOTE WBGLW					
Status of EUT	Engineering sample					
Power Supply Rating	2.5VDC to 5.5VDC					
Temperature Operating Range	-35°C to 75°C					
Modulation Type	GSM			GMSK		
	GPRS			GMSK		
	EDGE			GMSK, 8PSK		
	WCDMA			UL: QPSK DL: QPSK,16QAM		
	LTE			UL: QPSK,16QAM DL: QPSK,16QAM, 64QAM		
Operating Frequency	2g: GSM 850, PCS1900					
	3g: B2, B4, B5					
	4g: B2, B4, B5, B7, B12, B13, B66					
	Frequency range	Uplink	824	849	MHz	Module transmit
	GSM 850	Downlink	869	894	MHz	Module receive
	Frequency range	Uplink	1850	1910	MHz	Module transmit
	PCS 1900	Downlink	1930	1990	MHz	Module receive
	Frequency range	Uplink	1850	1910	MHz	Module transmit
	FDD Band 2 (1900 MHz)	Downlink	1930	1990	MHz	Module receive
	Frequency range	Uplink	1710	1755	MHz	Module transmit
	FDD Band 4 (1700 MHz)	Downlink	2110	2155	MHz	Module receive
	Frequency range	Uplink	824	849	MHz	Module transmit
	FDD Band 5 (850 MHz)	Downlink	869	894	MHz	Module receive
	Frequency range	Uplink	2500	2570	MHz	Module transmit
	FDD Band 7 (2600 MHz)	Downlink	2620	2690	MHz	Module receive
Frequency range	Uplink	699	716	MHz	Module transmit	
FDD Band 12 (700 MHz)	Downlink	729	746	MHz	Module receive	
Frequency range	Uplink	777	787	MHz	Module transmit	
FDD Band 13 (750 MHz)	Downlink	746	756	MHz	Module receive	
Frequency range	Downlink	2110	2200	MHz	Module receive	
FDD Band 66 (2500 MHz)						

BT/WLAN Module	<p>3.4 BT/WLAN Module</p> <table border="1"> <tr> <td>Model</td> <td>UGKZ7A10</td> </tr> <tr> <td>Manufacturer</td> <td>ALPS</td> </tr> <tr> <td rowspan="6">WIFI</td> <td>Frequency</td> <td>2412 to 2472MHz for 802.11b/g/n</td> </tr> <tr> <td>Channel Bandwidth</td> <td>20 MHz</td> </tr> <tr> <td>Modulation</td> <td>802.11b – BPSK, QPSK, CCK, DSSS 802.11g – BPSK, QPSK, 16/64QAM, OFDM 802.11n – HT mode MCS0-7</td> </tr> <tr> <td>Data rate max</td> <td>802.11b – 11Mbps 802.11g – 54Mbps 802.11n – 72.2Mbps</td> </tr> <tr> <td>Output Level</td> <td>802.11b – +15dBm 802.11g – +13dBm 802.11n – +11dBm</td> </tr> <tr> <td>Sensitivity</td> <td>802.11b – -90dBm 802.11g – -74dBm 802.11n – -72dBm</td> </tr> <tr> <td rowspan="2">BT</td> <td>Frequency</td> <td>2402 -2480MHz</td> </tr> <tr> <td>Channel Spacing</td> <td>Normal mode – 1MHz BLE mode –2MHz</td> </tr> </table>	Model	UGKZ7A10	Manufacturer	ALPS	WIFI	Frequency	2412 to 2472MHz for 802.11b/g/n	Channel Bandwidth	20 MHz	Modulation	802.11b – BPSK, QPSK, CCK, DSSS 802.11g – BPSK, QPSK, 16/64QAM, OFDM 802.11n – HT mode MCS0-7	Data rate max	802.11b – 11Mbps 802.11g – 54Mbps 802.11n – 72.2Mbps	Output Level	802.11b – +15dBm 802.11g – +13dBm 802.11n – +11dBm	Sensitivity	802.11b – -90dBm 802.11g – -74dBm 802.11n – -72dBm	BT	Frequency	2402 -2480MHz	Channel Spacing	Normal mode – 1MHz BLE mode –2MHz
Model	UGKZ7A10																						
Manufacturer	ALPS																						
WIFI	Frequency	2412 to 2472MHz for 802.11b/g/n																					
	Channel Bandwidth	20 MHz																					
	Modulation	802.11b – BPSK, QPSK, CCK, DSSS 802.11g – BPSK, QPSK, 16/64QAM, OFDM 802.11n – HT mode MCS0-7																					
	Data rate max	802.11b – 11Mbps 802.11g – 54Mbps 802.11n – 72.2Mbps																					
	Output Level	802.11b – +15dBm 802.11g – +13dBm 802.11n – +11dBm																					
	Sensitivity	802.11b – -90dBm 802.11g – -74dBm 802.11n – -72dBm																					
BT	Frequency	2402 -2480MHz																					
	Channel Spacing	Normal mode – 1MHz BLE mode –2MHz																					
Antenna Type	External																						

4 Configuration and Connections with EUT

4.1 Features of EUT

The EUT has been tested as an independent unit together with other necessary accessories or support units. The following support units or accessories were used to form a representative test configuration during the tests.

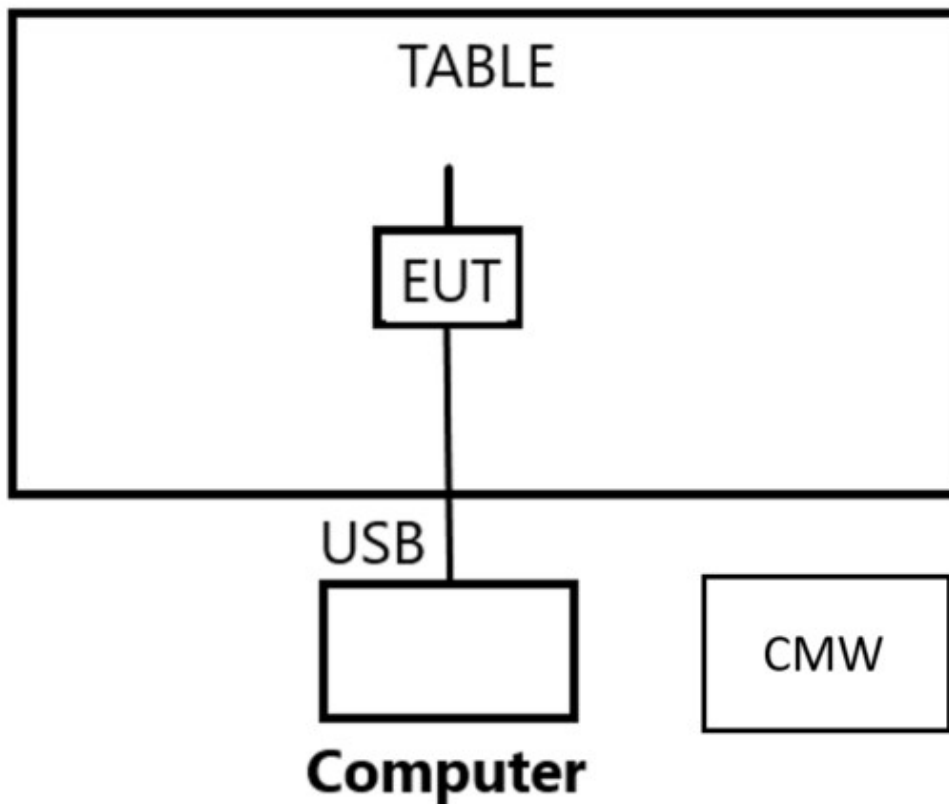

5 Emissions

Testing was performed in accordance with FCC KDB 996369 D04 Module Integration Guide v02. These test methods are listed under the laboratory's A2LA Scope of Accreditation. This test measures the levels emanating from the EUT, thus evaluating the potential for the EUT to cause radio frequency interference to other electronic devices. Procedures described in section 8 of the standard were used.

5.1 Transmit Spurious Emissions

Transmitter spurious emissions are emissions outside the frequency range of the equipment when the equipment is in transmit mode; per requirement of 47 CFR Part 2, RSS-GEN, 47 CFR Part 22 Subpart H, RSS-132, 47 CFR Part 24 Subpart E, RSS-133.

5.1.1 Test Methodology

5.1.1.1 Preliminary Test

A test program that controls instrumentation and data logging was used to automate the preliminary RF emission test procedure. The frequency range of interest was divided into sub-ranges to yield a frequency resolution of approximately 120 kHz and provide a reading at each frequency for no more than 12° of turntable rotation. For each frequency sub-range the turntable was rotated 360° while peak emission data was recorded and plotted over the frequency range of interest in horizontal and vertical antenna polarization's.

Preliminary emission profile testing was performed inside the anechoic chamber. The EUT was placed on a 1.0m x 1.5m non-conductive table 80cm (<1 GHz) and 150cm (>1 GHz) above the floor. The EUT was positioned as shown in the setup photographs. The receiving antenna was placed at a distance of 3m at a fixed height of 1m. Measurement equipment was located outside of the chamber. A video camera was placed inside the chamber to view the EUT.

Pres-scans were performed to determine the worst case configuration for data rate.

5.1.1.2 Final Test

For each frequency measured, the peak emission was maximized by manipulating the receiving antenna from 1 to 4 meters above the ground plane and placing it at the position that produced the maximum signal strength reading. The turntable was then rotated through 360° while observing the peak signal and placing the EUT at the position that produced maximum radiation. The six highest emissions relative to the limit were measured unless such emissions were more than 20 dB below the limit. If less than six emissions are within 20 dB of the limit, than the noise level of the receiver is measured at frequencies where emissions are expected. Multiples of all oscillator and microprocessor frequencies were also checked.

Final testing was performed on an NSA compliant test site. The EUT was placed on a 1.0m x 1.5m non-conductive table 80cm (<1 GHz) and 150cm (>1 GHz) above the ground plane. The placement of EUT and cables were the same as for preliminary testing and is shown in the setup photographs.

The final scans performed with the gate on the up-right position

Table 2: Test Modes

Operational Band	Modes
LTE Band 5	Cellular radio @ LTE B5 (UL = 847.5MHz, BW = 3MHz, QPSK)
WCDMA Band 2	Cellular radio @ WCDMA B2 (UL = 1852.4MHz, BW = 5MHz, DS-CDMA)
GSM1900	Cellular radio @ GSM1900; Ch 512 (UL = 1850.2MHz, BW = 59.6MHz, GMSK)

Test Setup:

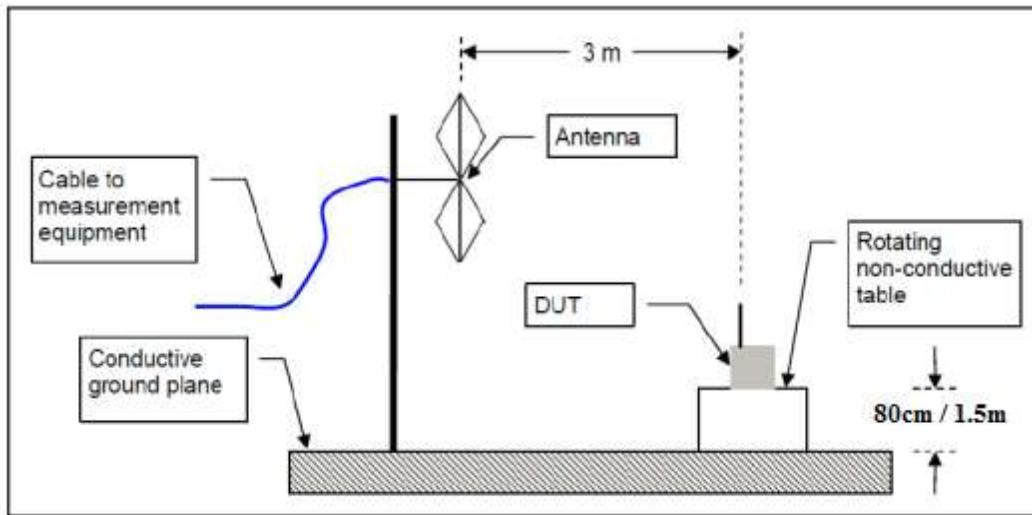

5.1.2 Transmitter Spurious Emission Limit

The required emission stated in Table 1 (-13dBm) is equivalent to 82.2 dBuV/m at 3 meter distance.

5.1.3 Test Results

The final measurement data was taken under the worst case operating modes, configurations, and/or cable positions. It also reflects the results including any modifications and/or special accessories listed in Sections 1.4 and test plan.

As originally tested, the EUT was found to be compliant to the requirements of the test standard(s).

Radiated Emissions (30MHz-1GHz) - LTE Band 5											
EUT Name		NOTE					Date		07/25/2023		
EUT Model		WWXD/WBGLW					Temp / Hum in		23°C / 40% RH		
Standard		CFR47 Part 2.1053; 22.917 RSS-GEN 5, 6.13 RSS-132, 5.5					RBW / VBW		120kHz / 300kHz		
Dist/Ant Used		3m / JB6					Performed by		Brandon Quan		
Freq	Raw	Corrd'	Level	Det	Pol	Hght	Azt	Limit	Margin	Result	
MHz	dBuV/m	dB	dBuV/m		H/V	cm	deg	dBuV/m	dB		
879.264	22	33	55	PK	H	211	348	82.20	27.2	Pass	
296.635	15.6	21.9	37.5	PK	H	209	140	82.20	44.7	Pass	
531.165	0.2	27.6	27.8	PK	H	245	321	82.20	54.4	Pass	
360.155	3.7	23.4	27.1	PK	V	100	324	82.20	55.1	Pass	
75.989	14.4	14	28.4	PK	H	250	197	82.20	53.8	Pass	
38.13	23.1	20.1	43.2	PK	V	106	22	82.20	39	Pass	
Spec Margin = Limit - Level, Level = Raw+ Cbl+ CF ± Uncertainty											
CF= Amp Gain + ANT Factor											
Combined Standard Uncertainty $u_c(y) = \pm 4.91\text{dB}$ Expanded Uncertainty $U = ku_c(y)$ $k = 2$ for 95% confidence											
Notes: All emissions passed the spurious emission limit. Below 1GHz: RBW = 120 kHz and VBW = 300 kHz Above 1GHz: RBW = 1 MHz and VBW = 3 MHz											

Radiated Emissions (30MHz-1GHz) - LTE Band 5

EUT Name	NOTE	Date	07/25/2023
EUT Model	WWXD/WBGLW	Temp / Hum in	23°C / 40% RH
Standard	CFR47 Part 2.1053; 22.917	RBW / VBW	120kHz / 300kHz
	RSS-GEN 5, 6.13 RSS-132, 5.5	Performed by	Brandon Quan
Dist/Ant Used	3m / JB6		

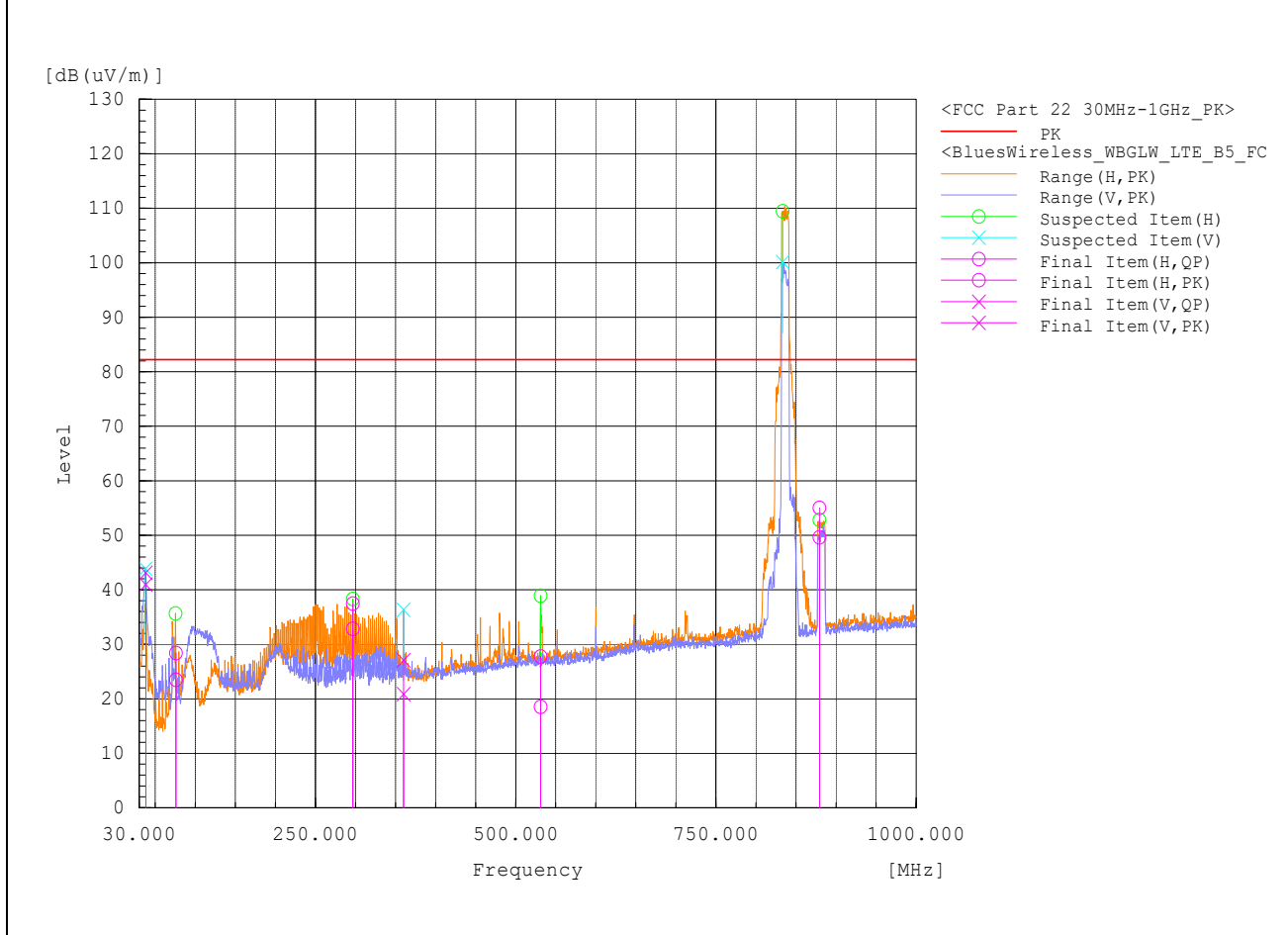

Radiated Emissions (1-18GHz) - LTE Band 5											
EUT Name		NOTE					Date		07/25/2023		
EUT Model		WWXD/WBGLW					Temp / Hum in		23°C / 40% RH		
Standard		CFR47 Part 2.1053; 22.917 RSS-GEN 5, 6.13 RSS-132, 5.5					RBW / VBW		1MHz / 3MHz		
Dist/Ant Used		3m / 3117					Performed by		Brandon Quan		
Freq	Raw	Corrd'	Level	Det	Pol	Hght	Azt	Limit	Margin	Result	
MHz	dBuV/m	dB	dBuV/m		H/V	cm	deg	dBuV/m	dB		
2509.31	61.3	-14.3	47	PK	V	208	64.8	82.2	35.2	Pass	
4789.684	51.4	-10.9	40.5	PK	H	125	235	82.2	41.7	Pass	
12165.95	45.4	-3	42.4	PK	H	207	212	82.2	39.8	Pass	
14868.83	46.1	-1.1	45	PK	V	136	312	82.2	37.2	Pass	
15663.65	44.3	-1.4	42.9	PK	V	207	303	82.2	39.3	Pass	
16680.86	44.5	0.4	44.9	PK	H	100	289	82.2	37.3	Pass	
Spec Margin = Limit - Level, Level = Raw+ Cbl+ CF ± Uncertainty											
CF= Amp Gain + ANT Factor											
Combined Standard Uncertainty $u_c(y) = \pm 4.91\text{dB}$ Expanded Uncertainty $U = ku_c(y)$ $k = 2$ for 95% confidence											
Notes: All emissions passed the spurious emission limit.											

Radiated Emissions (1-18GHz) - LTE Band 5

EUT Name	NOTE	Date	107/25/2023
EUT Model	WWXD/WBGLW	Temp / Hum in	23°C / 40% RH
Standard	CFR47 Part 2.1053; 22.917 RSS-GEN 5, 6.13 RSS-132, 5.5	RBW / VBW	1MHz / 3MHz
Dist/Ant Used	3m / 3117	Performed by	Brandon Quan

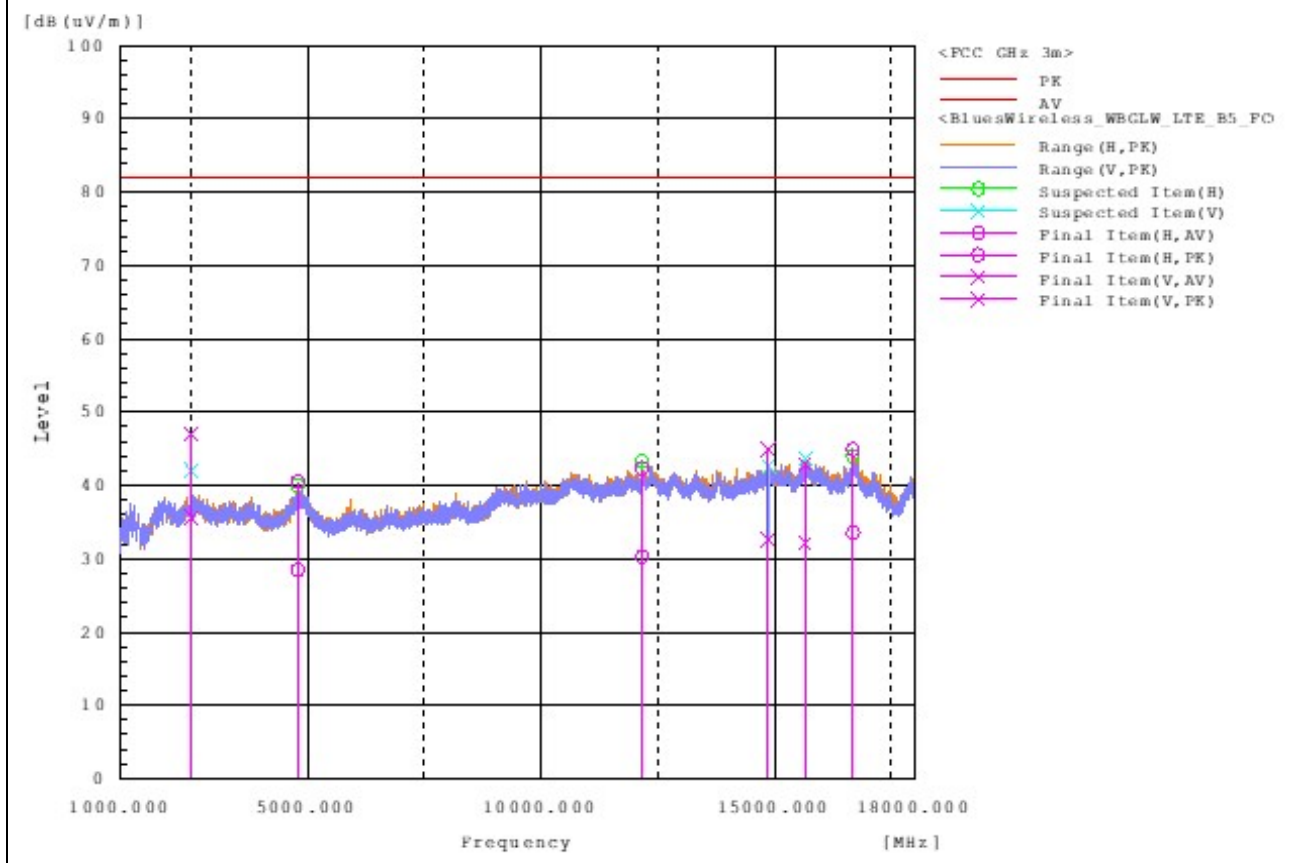

Radiated Emissions (30MHz-1GHz) – WCDMA B2											
EUT Name		NOTE					Date		07/25/2023		
EUT Model		WWXD/WBGLW					Temp / Hum in		23°C / 40% RH		
Standard		CFR47 Part 2.1053; 24.238 RSS-GEN 5, 6.13 RSS-133, 6.5					RBW / VBW		120kHz / 300kHz		
Dist/Ant Used		3m / JB6					Performed by		Brandon Quan		
Freq	Raw	Corrd'	Level	Det	Pol	Hght	Azt	Limit	Margin	Result	
MHz	dBuV/m	dB	dBuV/m		H/V	cm	deg	dBuV/m	dB		
37.955	22.7	20.3	43	PK	V	106	22.2	82.20	39.2	Pass	
73.612	18.7	14	32.7	PK	H	265	48	82.20	49.5	Pass	
111.626	10.9	19.5	30.4	PK	V	102	225	82.20	51.8	Pass	
267.2	14.4	21.1	35.5	PK	H	237	171	82.20	46.7	Pass	
452.725	6.5	25.8	32.3	PK	H	179	148	82.20	49.9	Pass	
994.502	0.7	34.6	35.3	PK	H	100	94.7	82.20	46.9	Pass	
Spec Margin = Limit - Level, Level = Raw+ Cbl+ CF ± Uncertainty CF= Amp Gain + ANT Factor											
Combined Standard Uncertainty $u_c(y) = \pm 4.91\text{dB}$ Expanded Uncertainty $U = ku_c(y)$ $k = 2$ for 95% confidence											
Notes: All emissions passed the spurious emission limit.											

Radiated Emissions (30MHz-1GHz) – WCDMA B2

EUT Name	NOTE	Date	07/25/2023
EUT Model	WWXD/WBGLW	Temp / Hum in	23°C / 40% RH
Standard	CFR47 Part 2.1053; 24.238 RSS-GEN 5, 6.13 RSS-133, 6.5	RBW / VBW	120kHz / 300kHz
Dist/Ant Used	3m / JB6	Performed by	Brandon Quan

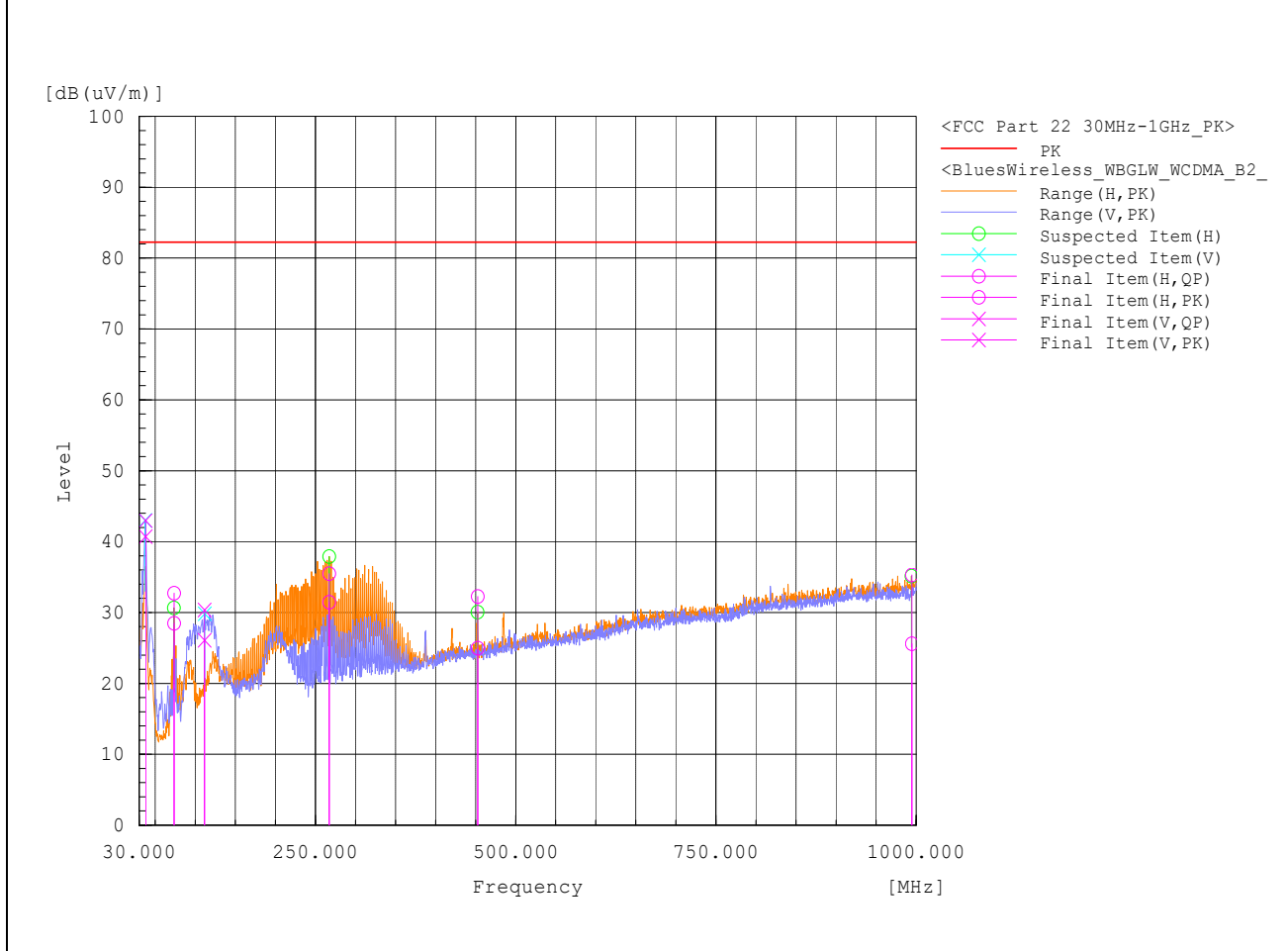

Radiated Emissions (1-18GHz) - WCDMA B2											
EUT Name		NOTE					Date		07/25/2023		
EUT Model		WWXD/WBGLW					Temp / Hum in		23°C / 40% RH		
Standard		CFR47 Part 2.1053; 24.238 RSS-GEN 5, 6.13 RSS-133, 6.5					RBW / VBW		1MHz / 3MHz		
Dist/Ant Used		3m / 3117					Performed by		Brandon Quan		
Freq	Raw	Corrd'	Level	Det	Pol	Hght	Azt	Limit	Margin	Result	
MHz	dBuV/m	dB	dBuV/m		H/V	cm	deg	dBuV/m	dB		
1851.416	62.6	-15.4	74	PK	H	160	57.7	82.2	35	Pass	
2010.181	56.1	-14.8	74	PK	V	250	288	82.2	40.9	Pass	
4859.933	51.8	-11	74	PK	V	172	281	82.2	41.4	Pass	
13778.36	45.8	-2.7	74	PK	H	100	235	82.2	39.1	Pass	
15694.14	43.9	-1.3	74	PK	H	100	203	82.2	39.6	Pass	
16760.61	43.7	0.5	74	PK	V	148	0.9	82.2	38	Pass	
Spec Margin = Limit - Level, Level = Raw+ Cbl+ CF ± Uncertainty											
CF= Amp Gain + ANT Factor											
Combined Standard Uncertainty $u_c(y) = \pm 4.91\text{dB}$ Expanded Uncertainty $U = ku_c(y)$ $k = 2$ for 95% confidence											
Notes: All emissions passed the spurious emission limit.											

Radiated Emissions (1-18GHz) – WCDMA B2

EUT Name	NOTE	Date	07/25/2023
EUT Model	WWXD/WBGLW	Temp / Hum in	23°C / 40% RH
Standard	CFR47 Part 2.1053; 24.238 RSS-GEN 5, 6.13 RSS-133, 6.5	RBW / VBW	1MHz / 3MHz
Dist/Ant Used	3m / 3117	Performed by	Brandon Quan

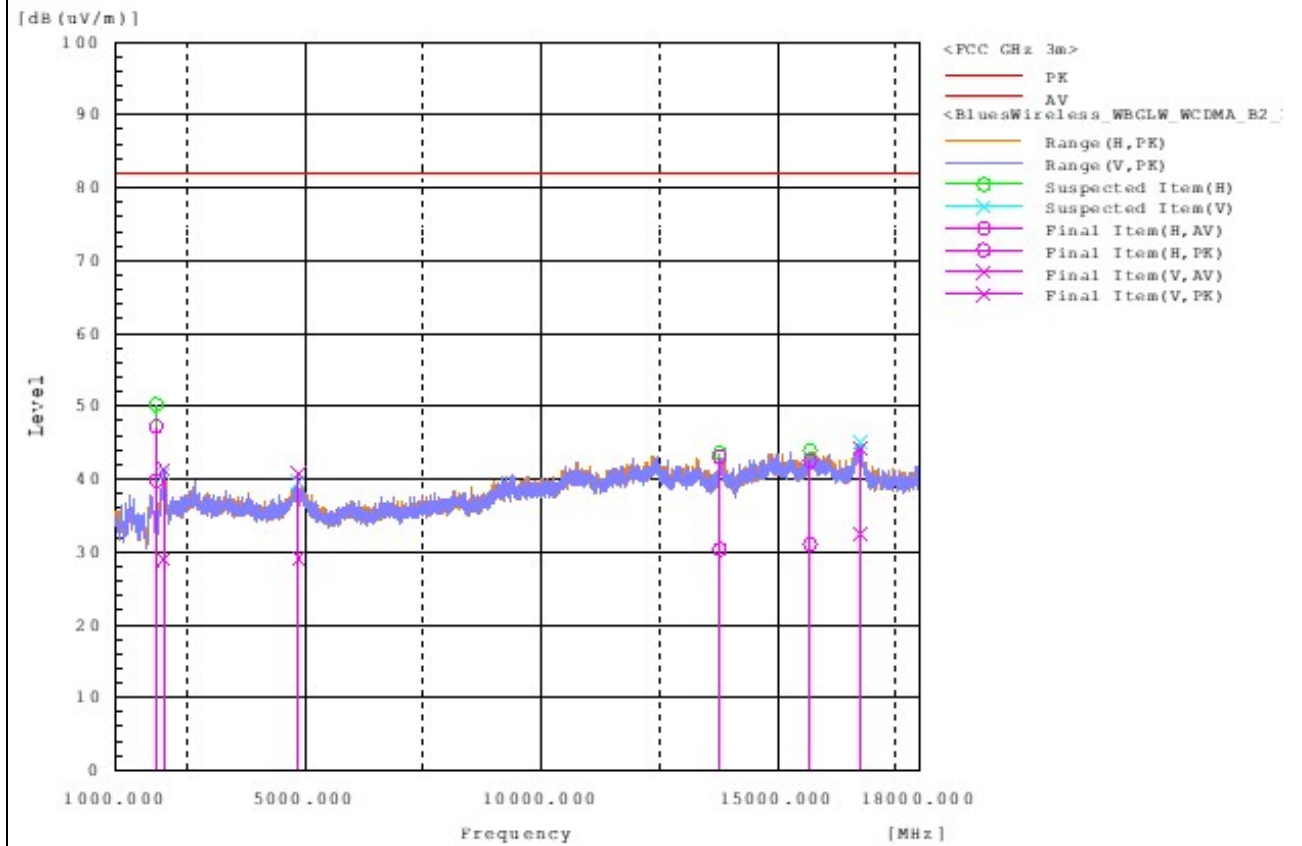

Radiated Emissions (30MHz-1GHz) – GSM 1900											
EUT Name		NOTE					Date		07/24/2023		
EUT Model		WWXD/WBGLW					Temp / Hum in		23°C / 40% RH		
Standard		CFR47 Part 2.1053; 24.238 RSS-GEN 5, 6.13 RSS-133, 6.5					RBW / VBW		120kHz / 300kHz		
Dist/Ant Used		3m / JB6					Performed by		Brandon Quan		
Freq	Raw	Corrd'	Level	Det	Pol	Hght	Azt	Limit	Margin	Result	
MHz	dBuV/m	dB	dBuV/m		H/V	cm	deg	dBuV/m	dB		
37.922	21.5	20.3	41.8	PK	V	102	28.2	82.20	40.4	Pass	
37.917	13.3	21.6	34.9	PK	H	212	79	82.20	47.3	Pass	
70.164	20.2	14.1	34.3	PK	H	314	197	82.20	47.9	Pass	
70.17	15.2	13.7	28.9	PK	V	171	309	82.20	53.3	Pass	
219.73	18.3	18.7	37	PK	H	100	168	82.20	45.2	Pass	
Spec Margin = Limit - Level, Level = Raw+ Cbl+ CF ± Uncertainty CF= Amp Gain + ANT Factor											
Combined Standard Uncertainty $u_c(y) = \pm 4.91\text{dB}$ Expanded Uncertainty $U = ku_c(y)$ $k = 2$ for 95% confidence											
Notes: All emissions passed the spurious emission limit.											

Radiated Emissions (30MHz-1GHz) – GSM 1900

EUT Name	NOTE	Date	07/24/2023
EUT Model	WWXD/WBGLW	Temp / Hum in	23°C / 40% RH
Standard	CFR47 Part 2.1053; 24.238 RSS-GEN 5, 6.13 RSS-133, 6.5	RBW / VBW	120kHz / 300kHz
Dist/Ant Used	3m / JB6	Performed by	Brandon Quan

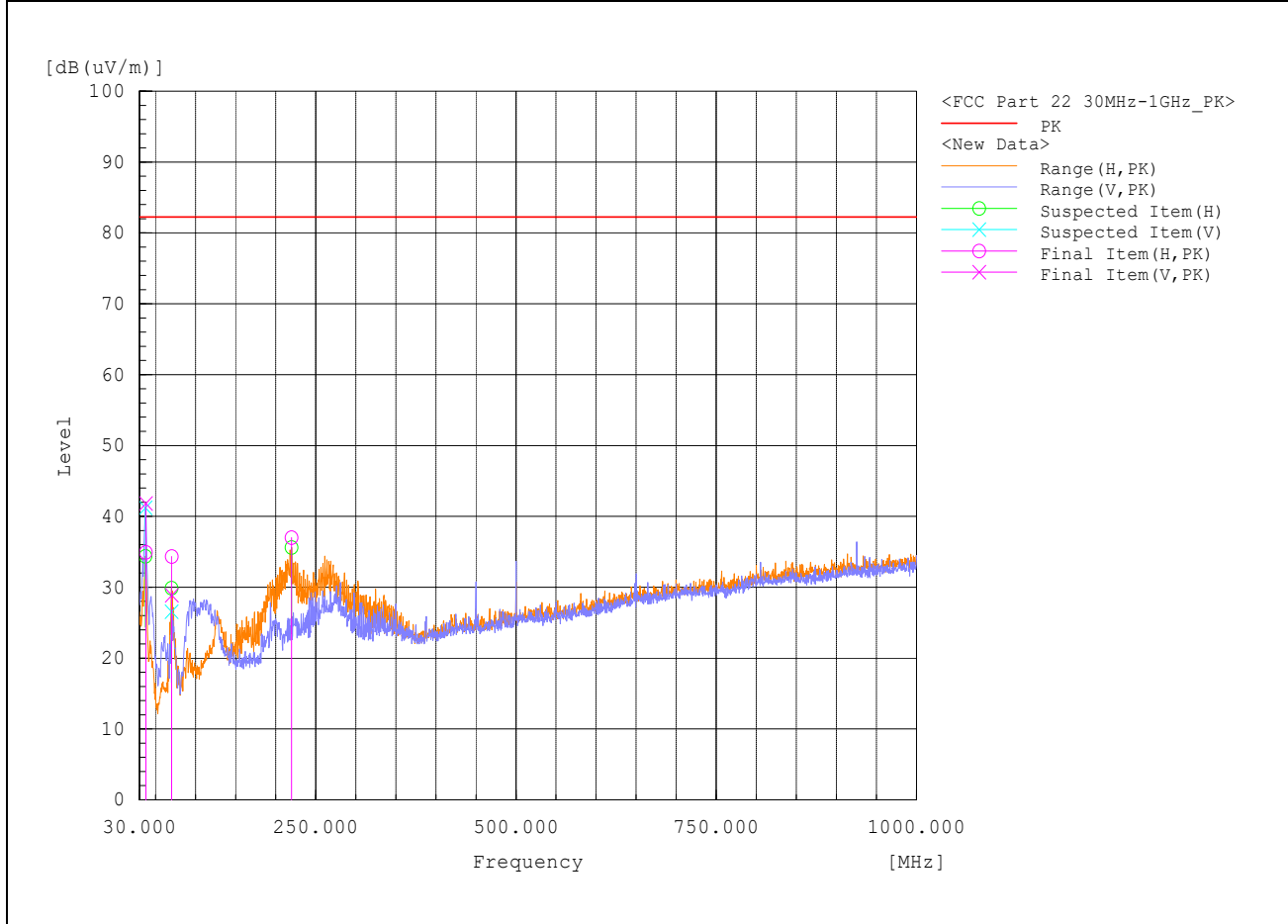

Radiated Emissions (1-18GHz) – GSM 1900											
EUT Name		NOTE					Date		07/24/2023		
EUT Model		WWXD/WBGLW					Temp / Hum in		23°C / 40% RH		
Standard		CFR47 Part 2.1053; 24.238 RSS-GEN 5, 6.13 RSS-133, 6.5					RBW / VBW		120kHz / 300kHz		
Dist/Ant Used		3m / JB6					Performed by		Brandon Quan		
Freq	Raw	Corrd'	Level	Det	Pol	Hght	Azt	Limit	Margin	Result	
MHz	dBuV/m	dB	dBuV/m		H/V	cm	deg	dBuV/m	dB		
1948.087	54.1	-14.7	39.4	PK	V	220	274	82.2	42.8	Pass	
3198.376	56.3	-13.4	42.9	PK	V	150	341	82.2	39.3	Pass	
4982.837	58.5	-12.2	46.3	PK	V	220	73	82.2	35.9	Pass	
5333.354	50.6	-13.7	36.9	PK	V	183	149	82.2	45.3	Pass	
12358.43	45.1	-2.6	42.5	PK	H	172	297	82.2	39.7	Pass	
16766.79	43.9	0.5	44.4	PK	V	172	41.1	82.2	37.8	Pass	
Spec Margin = Limit - Level, Level = Raw+ Cbl+ CF ± Uncertainty											
CF= Amp Gain + ANT Factor											
Combined Standard Uncertainty $u_c(y) = \pm 4.91\text{dB}$ Expanded Uncertainty $U = ku_c(y)$ $k = 2$ for 95% confidence											
Notes: All emissions passed the spurious emission limit.											

Radiated Emissions (1-18GHz) – GSM 1900

EUT Name	NOTE	Date	07/24/2023
EUT Model	WWXD/WBGLW	Temp / Hum in	23°C / 40% RH
Standard	CFR47 Part 2.1053; 24.238 RSS-GEN 5, 6.13 RSS-133, 6.5	RBW / VBW	1MHz / 3MHz
Dist/Ant Used	3m / 3117	Performed by	Brandon Quan

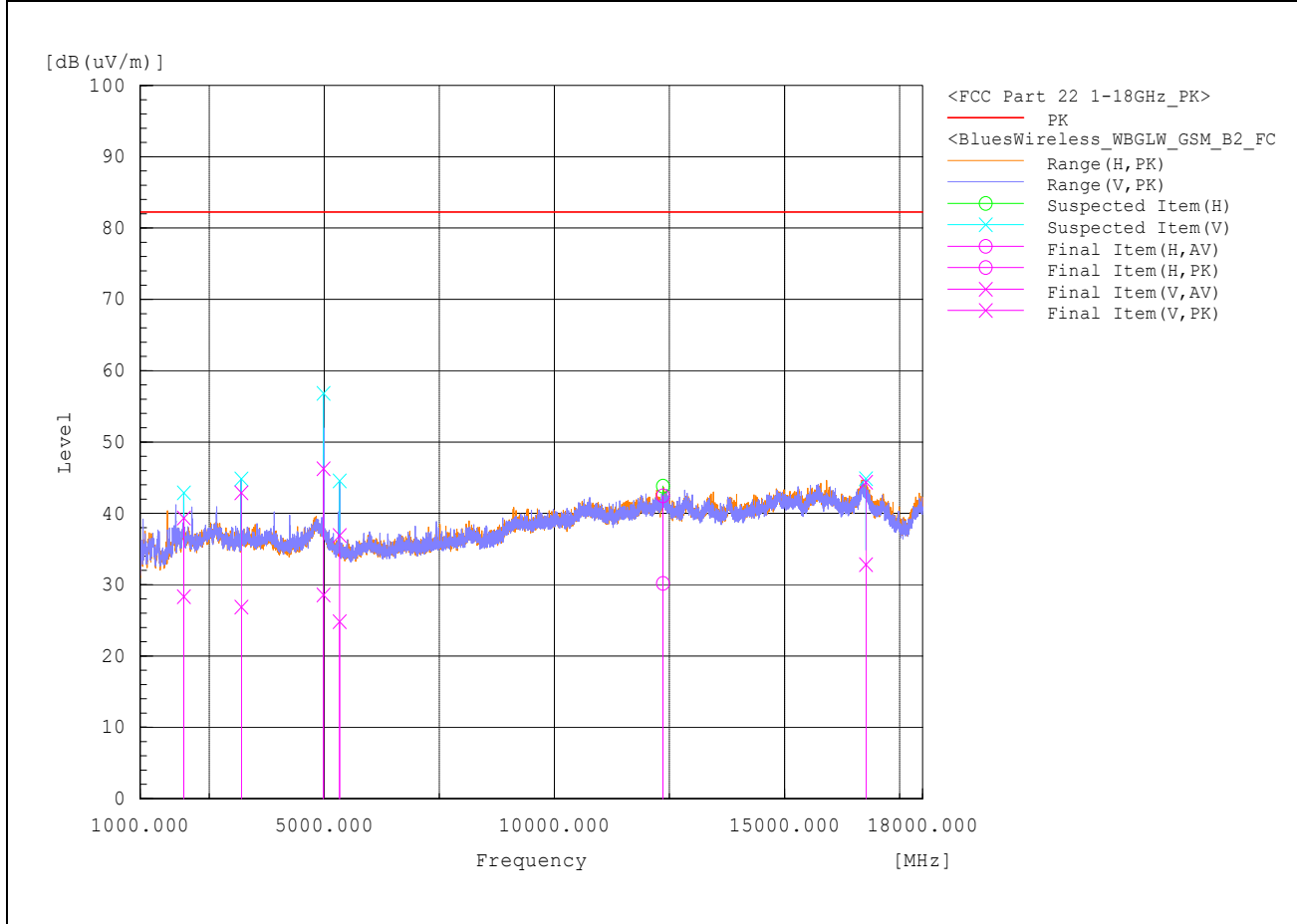

5.1.4 Sample Calculation

The field strength is calculated by subtracting the Amplifier Gain and adding the Cable Loss and Antenna Correction Factor to the measured reading. The basic equation is as follows:

$$\text{Field Strength (dB}\mu\text{V/m)} = \text{FIM} - \text{AMP} + \text{CBL} + \text{ACF}$$

Where: FIM = Field Intensity Meter (dB μ V)

AMP = Amplifier Gain (dB)

CBL = Cable Loss (dB)

ACF = Antenna Correction Factor (dB/m)

$$\mu\text{V/m} = 10^{\frac{\text{dB}\mu\text{V/m}}{20}}$$

6 EUT TEST SETUP Photos

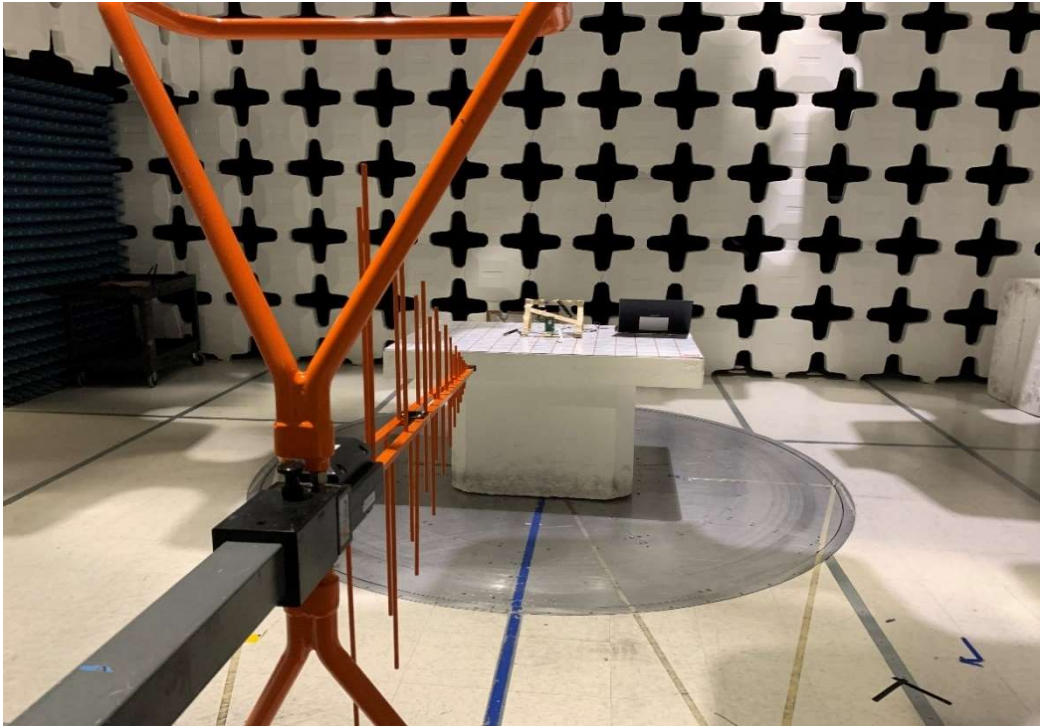

Radiated Emission 30 – 1000MHz (Front View)

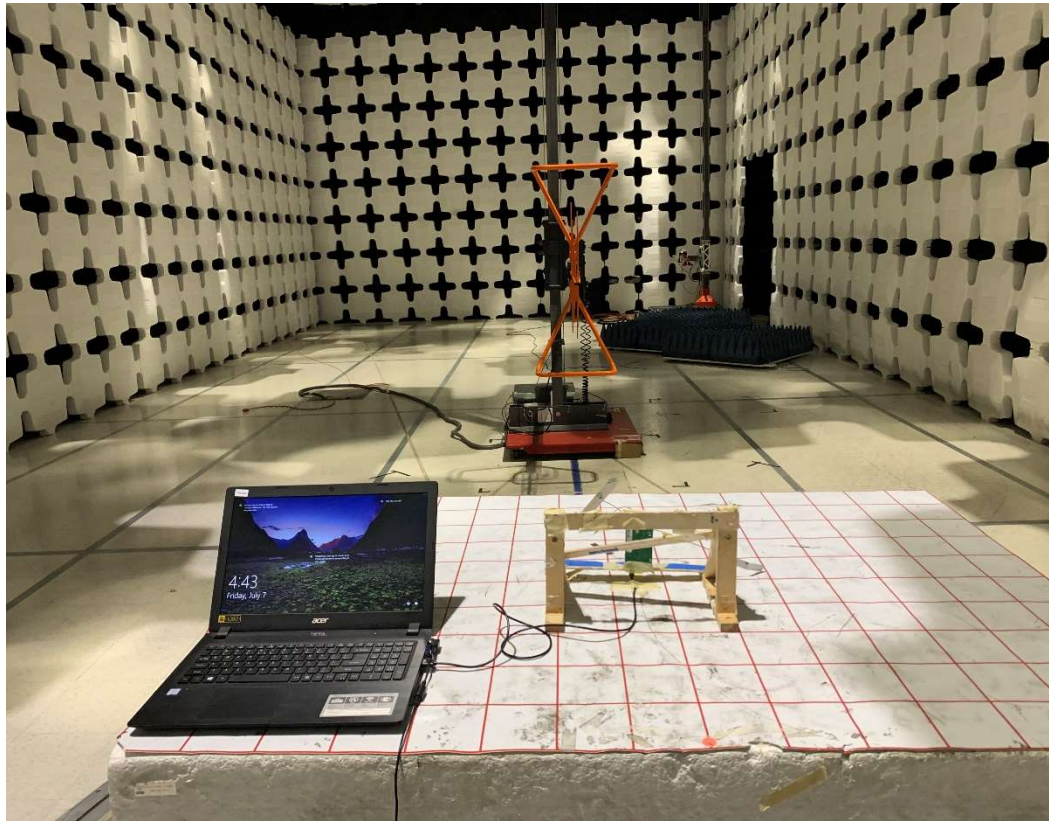

Radiated Emission 30 – 1000MHz (Rear View)

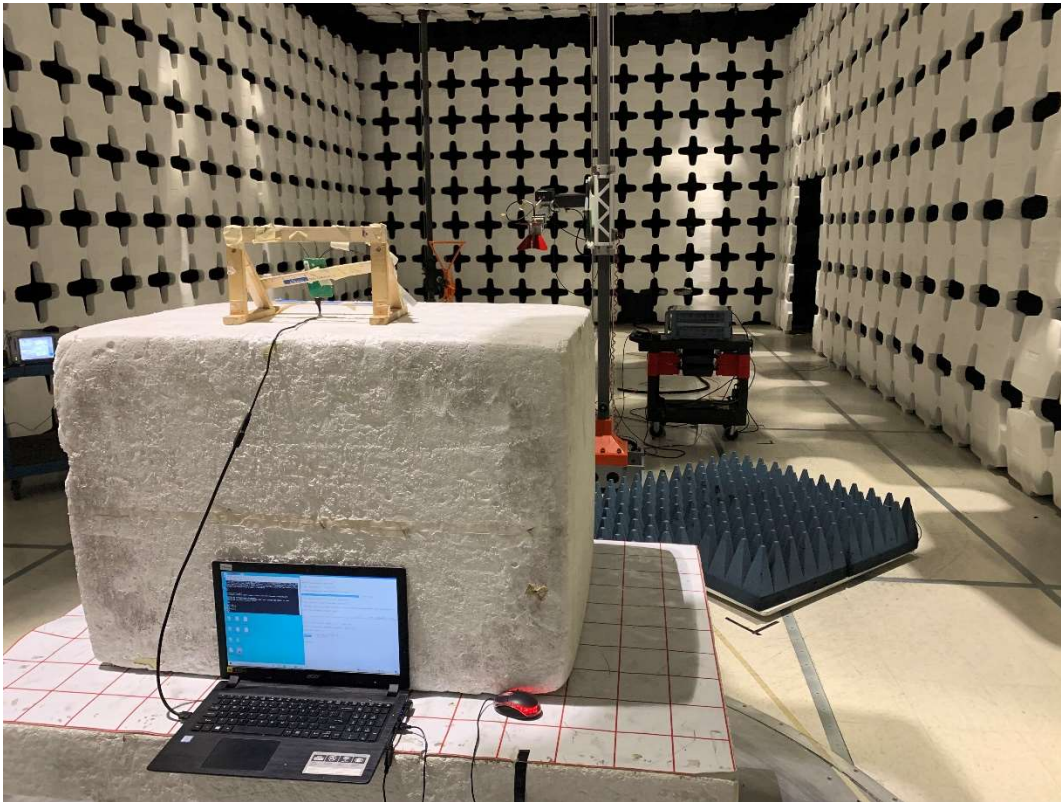

Radiated Emission 1 – 18GHz

7 Test Equipment List

7.1 Equipment List

Description & Manufacturer	Model No.	Serial No.	Cal. Date	Cal. Due
EMI Receiver Rohde and Schwarz	ESW44	1328.4100K- 101662-MH	09/20/2022	09/20/2023
Biconilog Antenna Sunol	JB6	A111717	09/22/2022	09/22/2023
Horn Antenna ETS-Lindgren	3117	218553	04/24/2023	04/24/2025
Preamplifier 1-18GHz The EMC Shop	PA18G-HA	001337	12/20/2022	12/20/2023
1850-1970MHz Notch Filter Micro-Tronics	BRM50714	G012	N/A*	N/A*

*Verified before use

Test software used: Toyo Corporation: Radiated Emission EP7/RE Ver 8.0.1 30

END OF REPORT